



US 20020063525A1

(19) **United States**

(12) **Patent Application Publication**

(10) **Pub. No.: US 2002/0063525 A1**

**Choi et al.**

(43) **Pub. Date:**

**May 30, 2002**

(54) **PLASMA SWITCHED ORGANIC ELECTROLUMINESCENT DISPLAY**

(52) **U.S. Cl.** ..... 313/582; 313/509

(76) **Inventors:** **Do-Hyun Choi**, Seoul (KR);  
**Byung-Hyun Byun**, Daejeon (KR);  
**Seung-Jun Yi**, Seoul (KR)

(57) **ABSTRACT**

Correspondence Address:  
**BIRCH STEWART KOLASCH & BIRCH**  
**PO BOX 747**  
**FALLS CHURCH, VA 22040-0747 (US)**

Described is a plasma switched organic electroluminescent display, which includes an electroluminescent part including a cathode layer, an electroluminescent layer on the cathode layer, and an anode layer on the electroluminescent layer, a first power supply unit connected electrically to the anode layer and disconnected electrically to the cathode layer so as to supply the electroluminescent layer with a first power, a plasma generating part generating a plasma wherein the plasma becomes contacted with the cathode layer, and a second power supply unit generating the plasma by supplying the plasma generating part with a second power, wherein the cathode layer is connected electrically to the first power supply unit through the plasma, thereby enabling to emit light by organic electroluminescence as well as drive the display by a low driving voltage using a plasma discharge as a switch.

(21) **Appl. No.:** 09/995,642

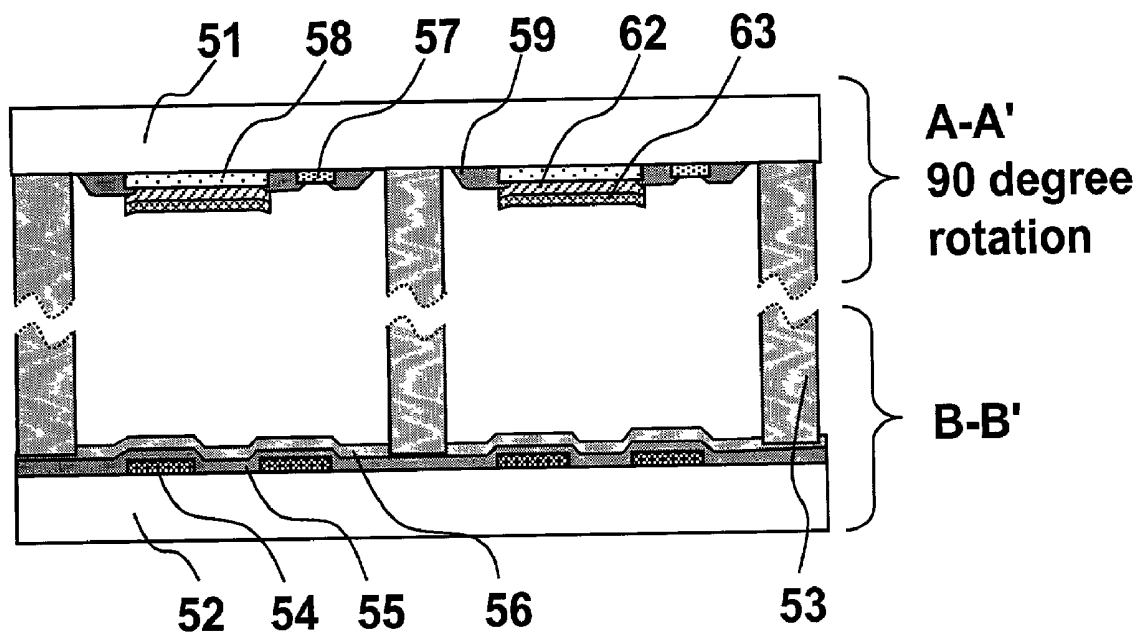
(22) **Filed:** Nov. 29, 2001

(30) **Foreign Application Priority Data**

Nov. 29, 2000 (KR) ..... 2000-71445  
Nov. 9, 2001 (KR) ..... 2001-69888

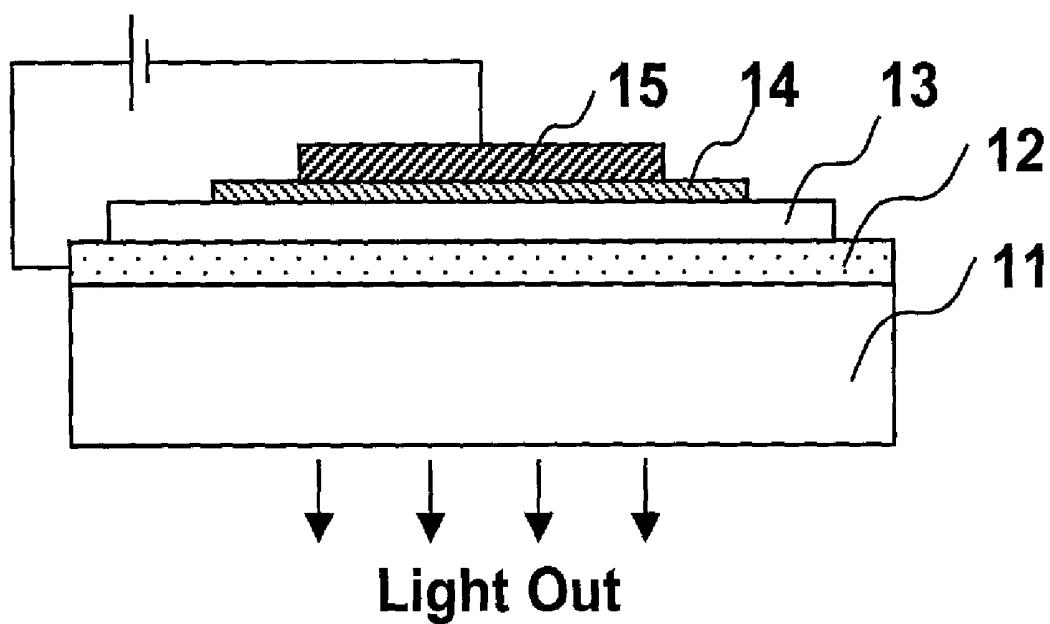
**Publication Classification**

(51) **Int. Cl.<sup>7</sup>** ..... H01J 17/49; H01J 1/62



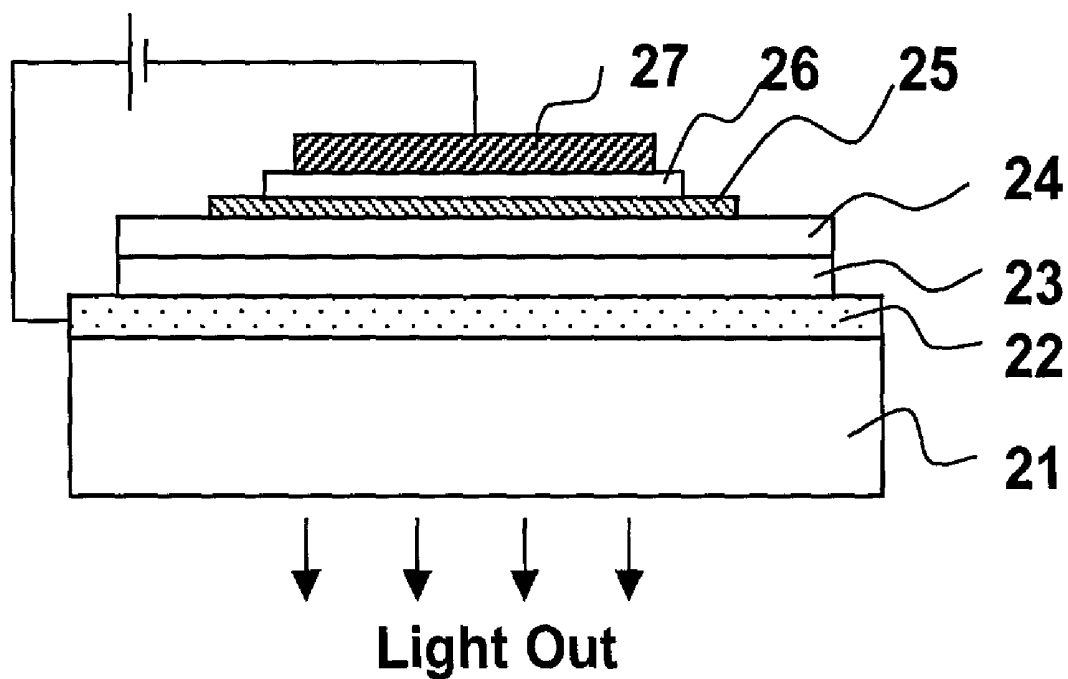
# FIG.1

## RELATED ART



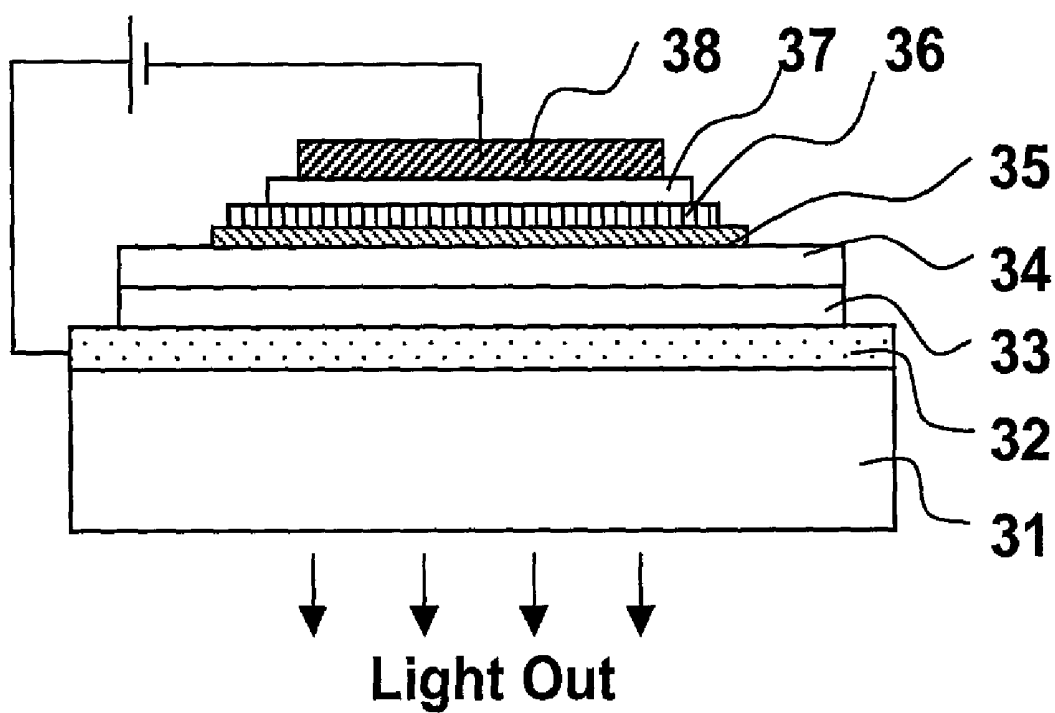
# FIG.2

## RELATED ART

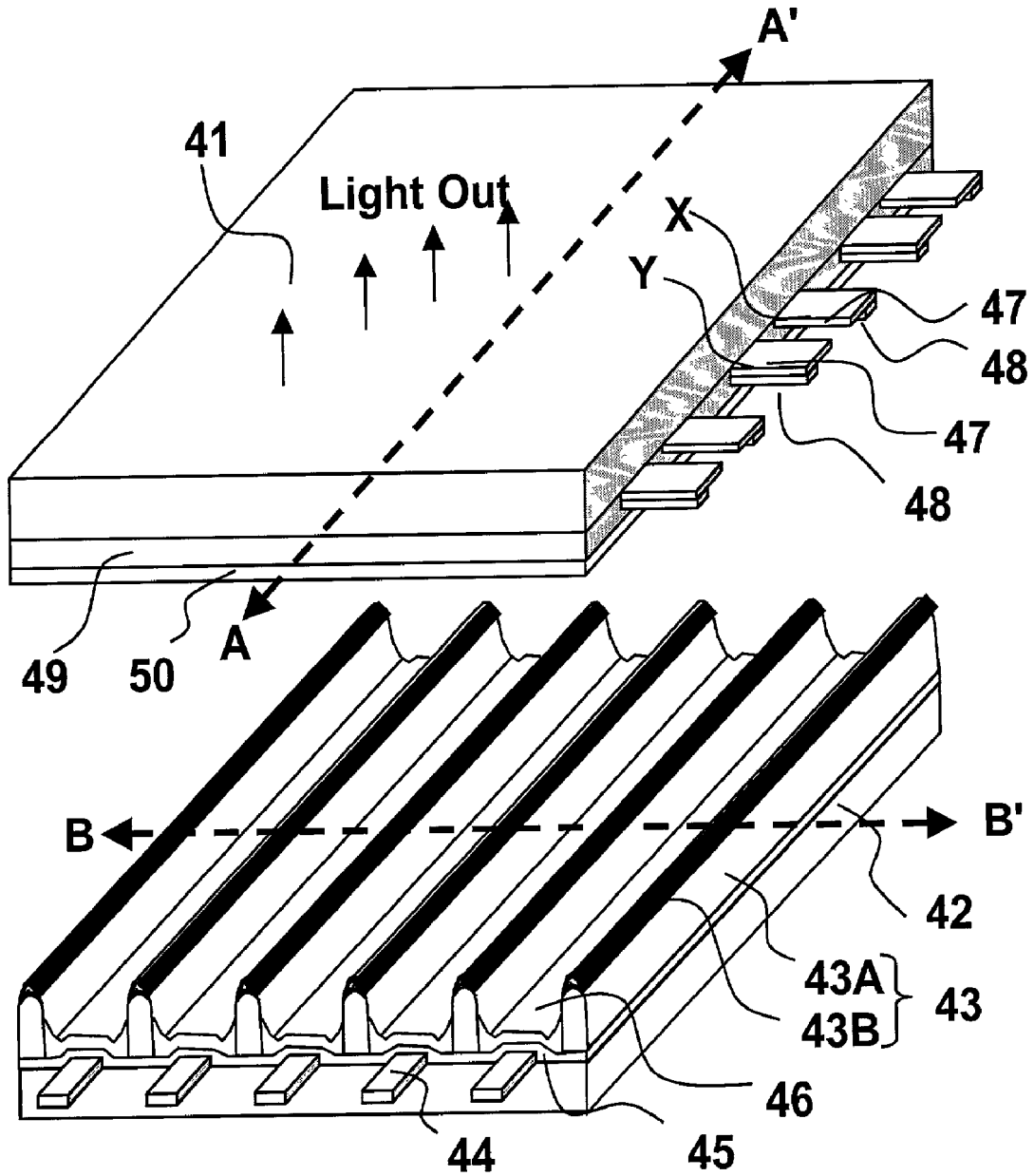


# FIG.3

## RELATED ART

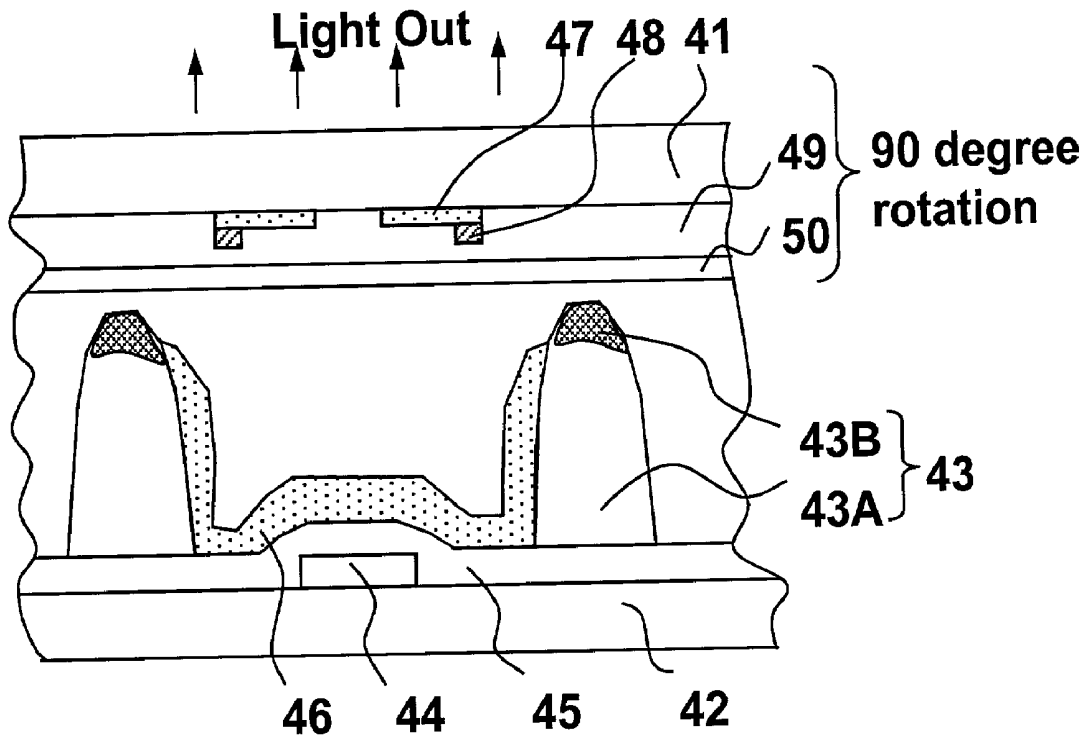


**FIG.4**  
**RELATED ART**

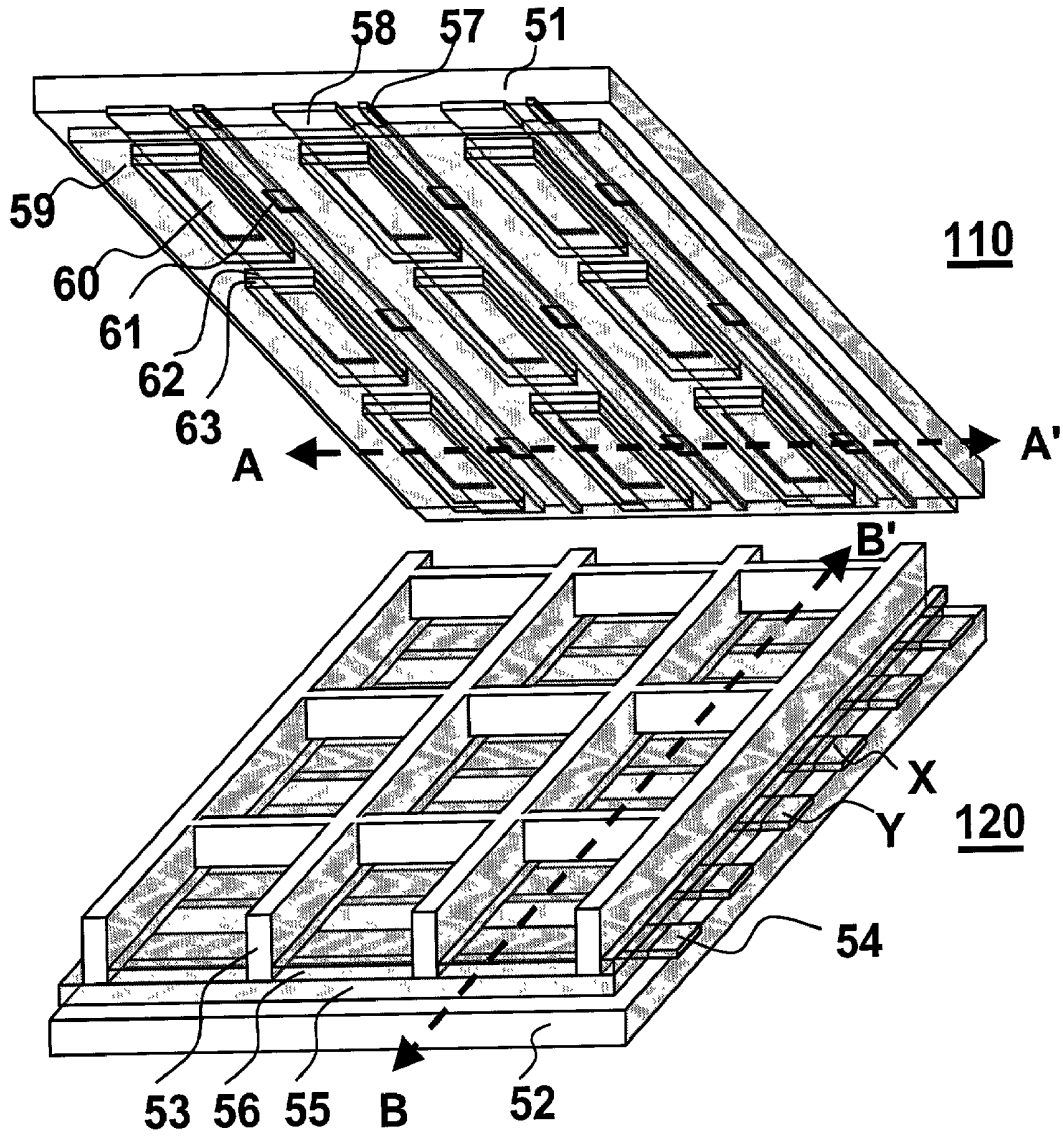


# FIG.5

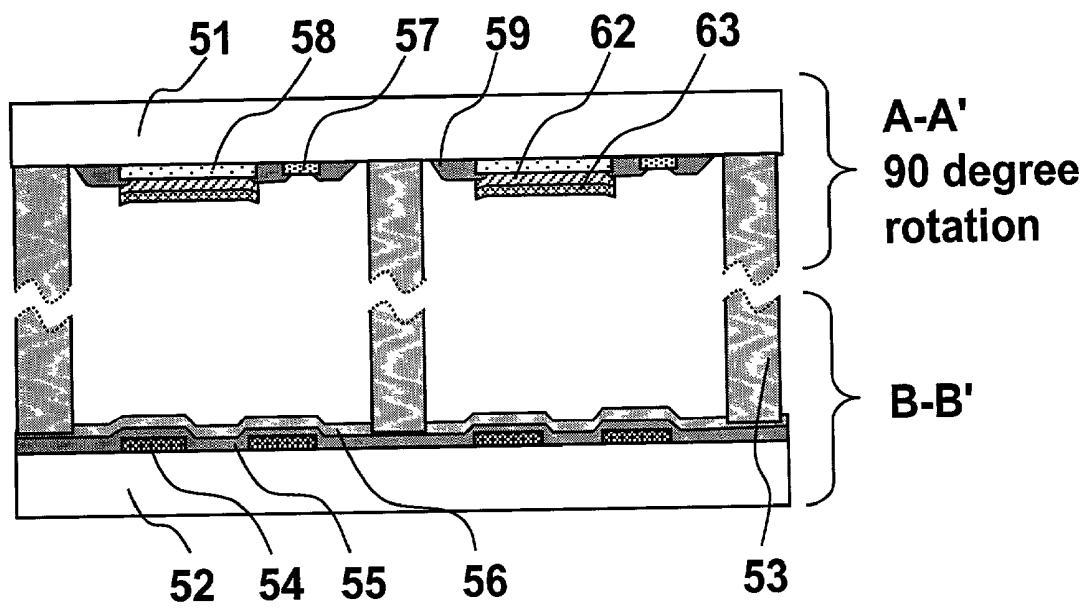
## RELATED ART



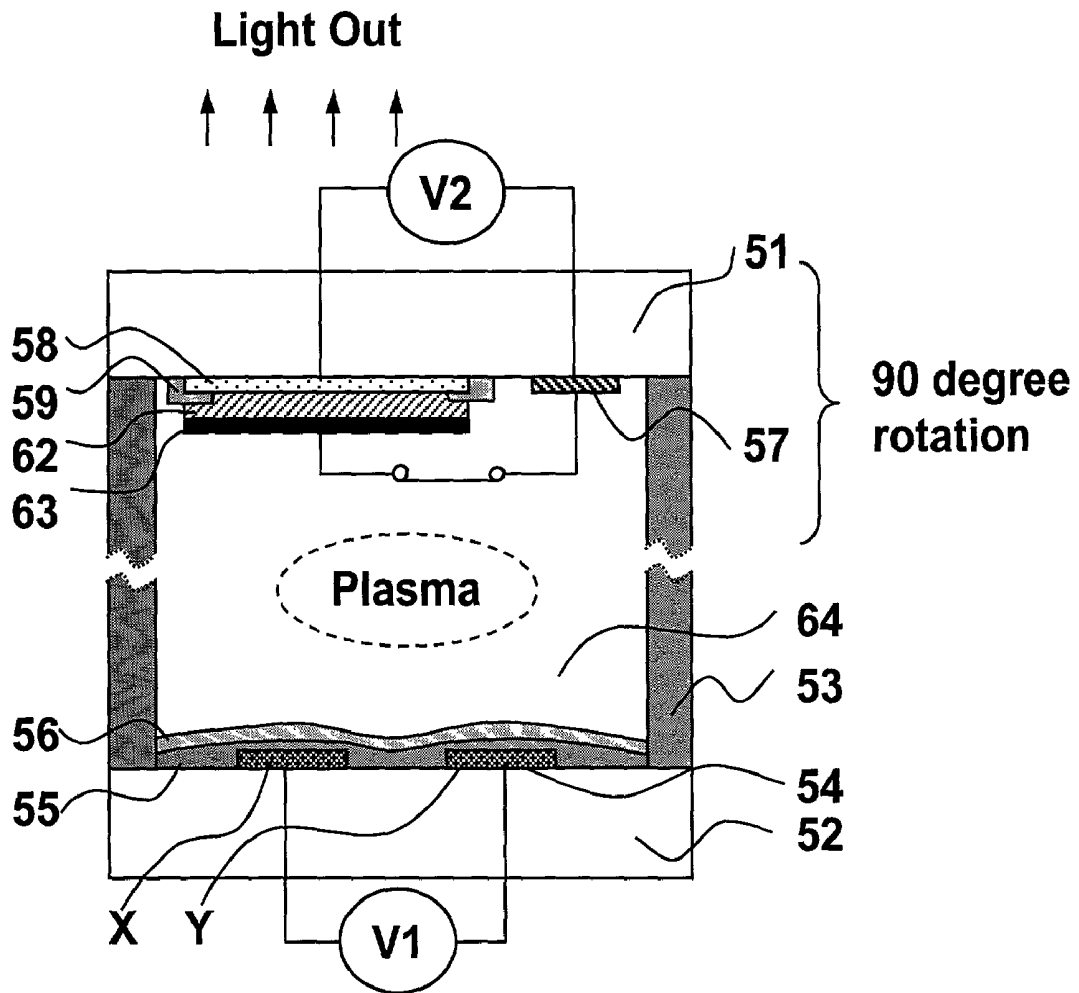
**FIG. 6**



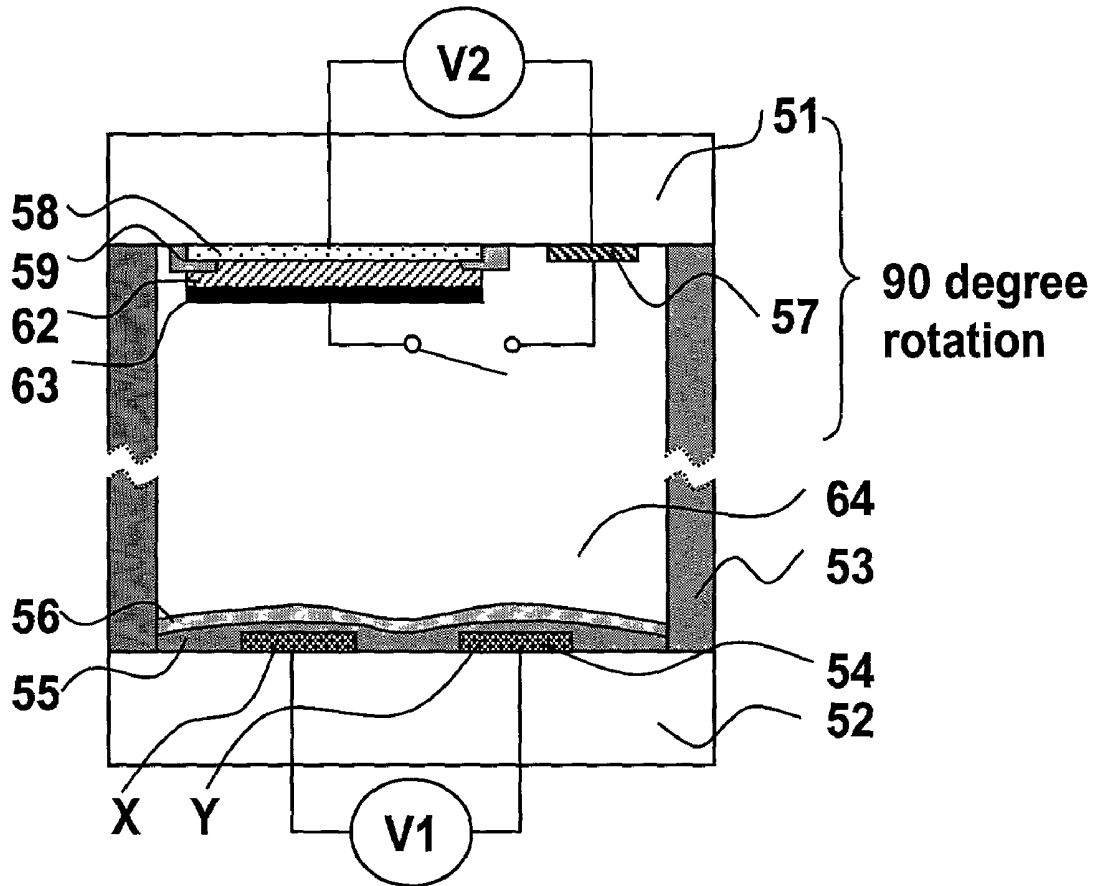
**FIG.7**



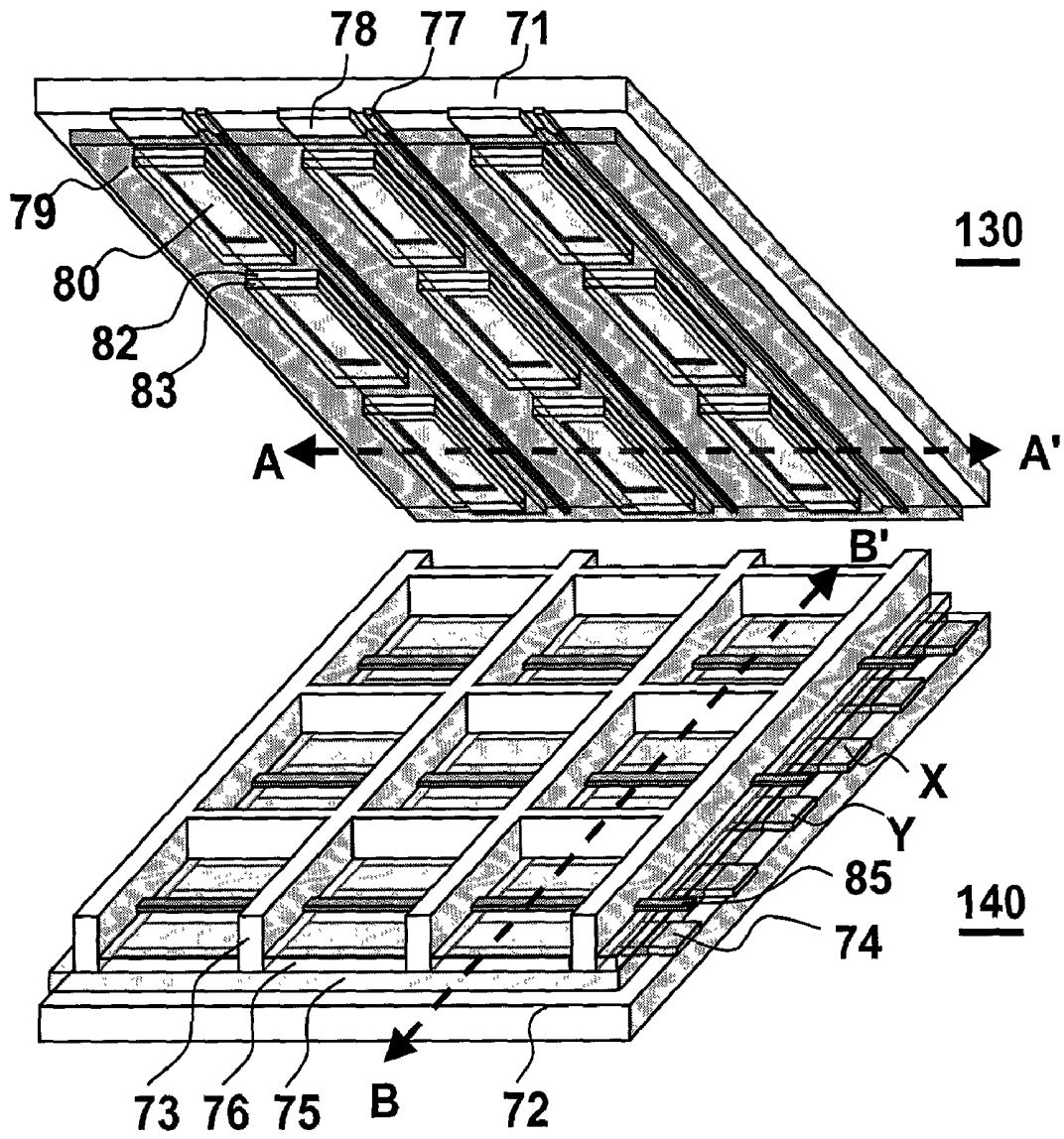
**FIG.8A**



**FIG.8B**



**FIG. 9**



**FIG.10**

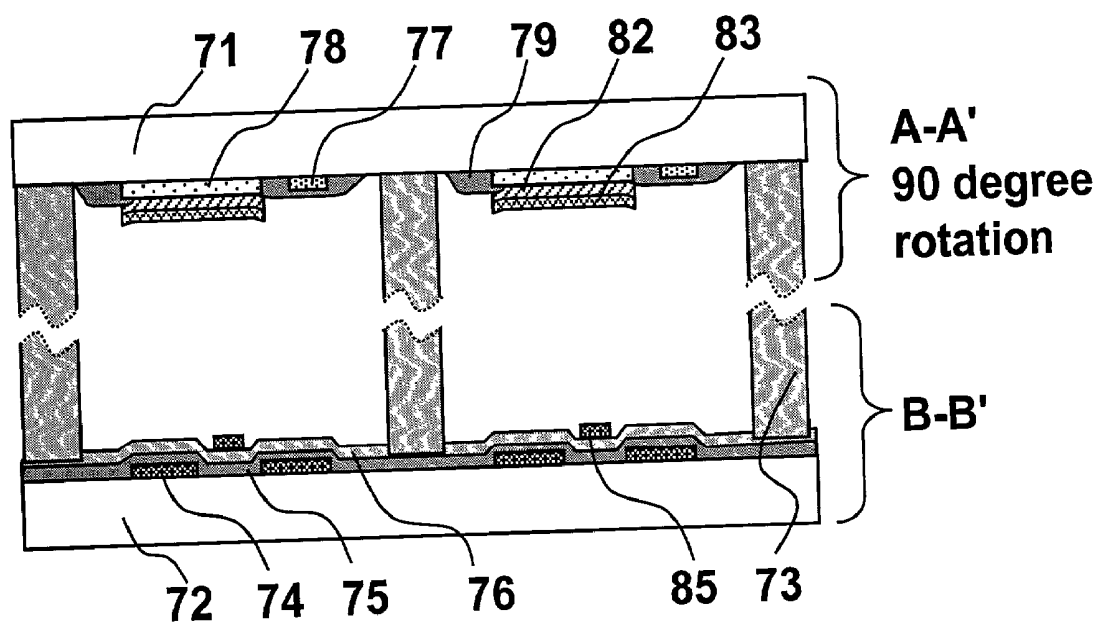
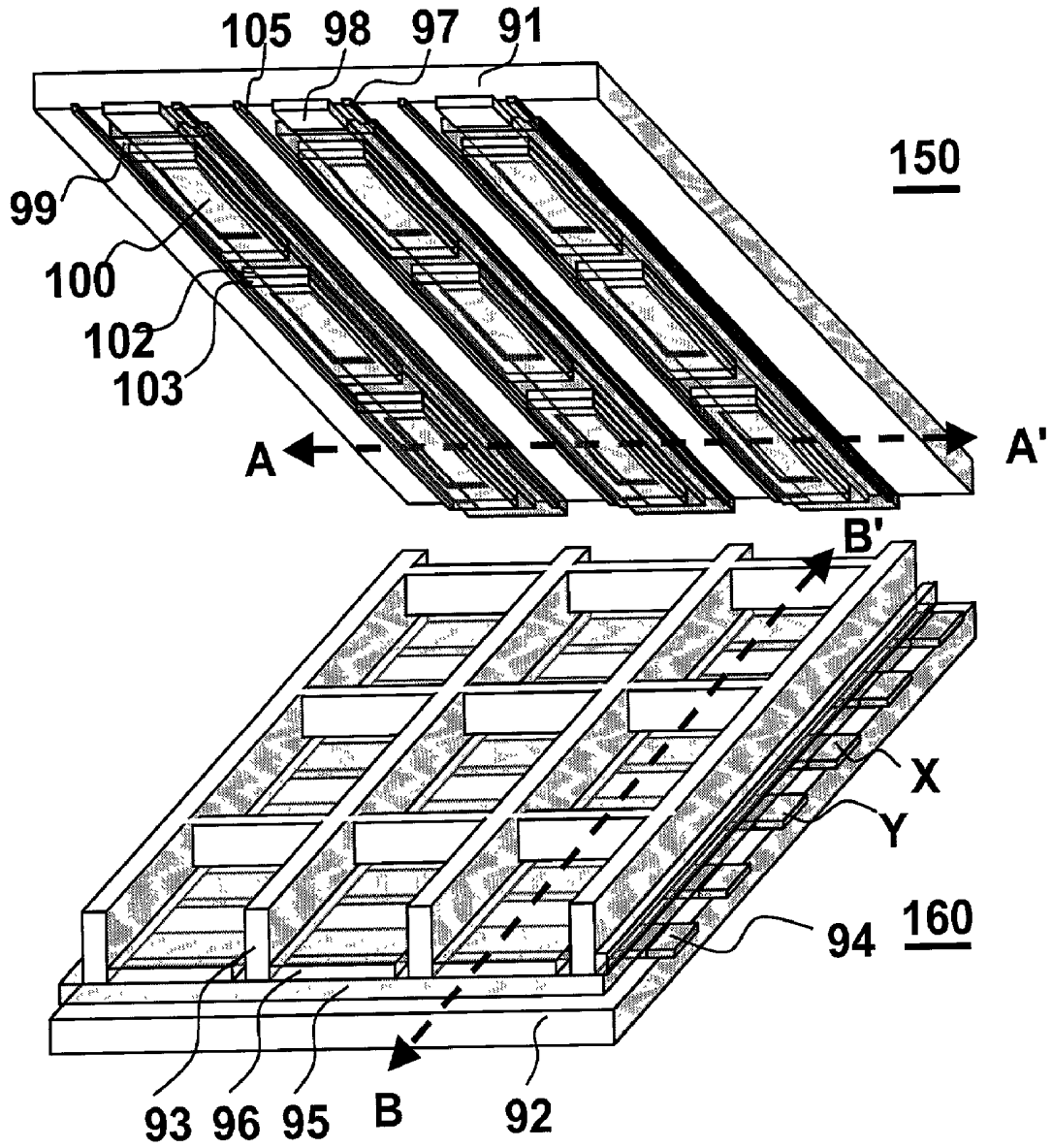
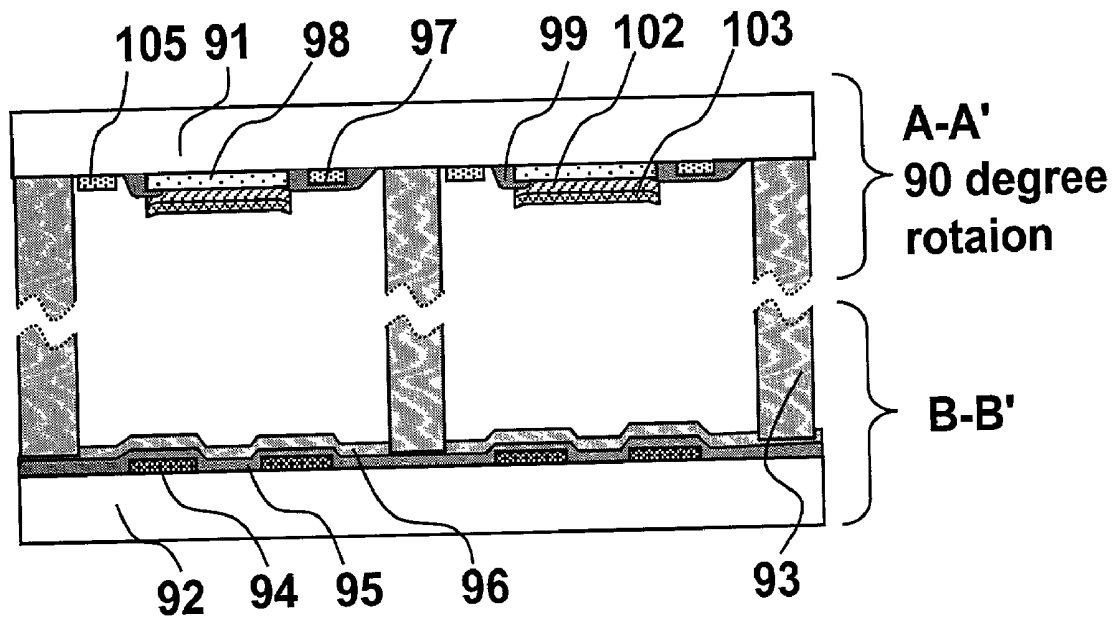


FIG.11



**FIG.12**



## PLASMA SWITCHED ORGANIC ELECTROLUMINESCENT DISPLAY

### BACKGROUND OF THE INVENTION

[0001] 1. Field of the Invention

[0002] The present invention relates to an organic electroluminescent display, and more particularly, to a plasma switched organic electroluminescent display driven by plasma switches.

[0003] 2. Background of the Related Art

[0004] As information telecommunication technologies have been greatly developed, a variety of demands for electronic display devices are highly increased to keep up with the developing information society. And, so does the demands for various displays. In order to satisfy the demands of the information society, for electronic display devices are required characteristics such as high-resolution, large-size, low-cost, high-performance, slim-dimension, and small-size and the like, for which new flat panel displays(FPD) are developed as substitutions for the conventional cathode ray tube(CRT).

[0005] The FPDs include LCD(liquid crystal display), ELD(electroluminescent display), PDP(plasma display panel), FED (field emission display), VFD (vacuum fluorescence display), and LED(light emitting display), and the like.

[0006] Compared to the light-receiving device such as LCD, ELD attracts attention as FPD having a response speed faster than that of the light-receiving display, excellent brightness by self-luminescence, easy fabrication thanks to a simple structure, and light weight/slim design. Thus, ELD is widely applied to various fields such as LCD backlight, mobile terminal, car navigation system(CNS), notebook computer, wall TV, and the like.

[0007] Such an ELD is divided into two categories, i.e. organic electroluminescent display(hereinafter abbreviated OELD) and inorganic electroluminescent display(hereinafter abbreviated IELD) in accordance with materials used for field luminescent layers respectively.

[0008] IELD, which emits light using the collisions of electrons accelerated by a high electric field, is classified into AC thin film ELD, AC thick film ELD, DC thin film ELD, and the like in accordance with thickness of the thin films and driving systems.

[0009] And, OELD, which emits light by a current flow, is classified into low-molecular OELD and high-molecular OELD.

[0010] FIG. 1 illustrates a cross-sectional view of a basic construction of OELD using a high molecular electroluminescent material according to a related art.

[0011] Referring to FIG. 1, stacked on a transparent substrate 11 such as a glass substrate in order are a transparent anode layer 12 formed of ITO (indium tin oxide) or IZO (indium zinc oxide), a hole transport layer 13, an electroluminescent layer 14, and a cathode layer 15 formed of a metal.

[0012] A material for the electroluminescent layer 14 is a conductive high molecule as a kind of conjugated polymers

disclosed on U.S. Pat. Nos. 5,399,502, and 5,807,627 such as poly(p-phenylenevinylene), i.e. PPV, poly(thiophene), poly(2,5-dialkoxyphenylene-vinylene, i.e. PDMeOPV or the like.

[0013] FIG. 2 illustrates a cross-sectional view of a basic construction of OELD using a low molecular electroluminescent material for fluorescence according to a related art.

[0014] Referring to FIG. 2, stacked on a transparent substrate 21 such as a glass substrate in order are a transparent anode layer 22 formed of ITO (indium tin oxide) or IZO (indium zinc oxide), a hole injection layer 23, a hole transport layer 24, an electroluminescent layer 25, an electron transport layer 26, and a cathode layer 27 formed of metal. The hole injection layer 23, hole transport layer 24, and electron transport layer 26 play an auxiliary role in increasing a luminescent efficiency of OELD. In this case, the electroluminescent layer 25 is formed of aluminum tris(8-hydroxyquinoline), i.e. Alq3, perylene, or the like, which are disclosed on U.S. Pat. Nos. 4,769,292 and 5,294,870.

[0015] FIG. 3 illustrates a cross-sectional view of a basic construction of OELD using a low molecular electroluminescent material for phosphorescence according to a related art.

[0016] Referring to FIG. 3, stacked on a transparent substrate 31 such as a glass substrate in order are a transparent anode layer 32 formed of ITO(indium tin oxide) or IZO(indium zinc oxide), a hole injection layer 33, a hole transport layer 34, an electroluminescent layer 35, a hole blocking layer 36, an electron transport layer 37, and a cathode layer 38 formed of metal.

[0017] The hole injection layer 33, hole transport layer 34, hole blocking layer 36, and electron transport layer 36 play an auxiliary role in increasing a luminescent efficiency of OELD. In this case, the electroluminescent layer 35 is formed of one of phosphorescent emitting materials disclosed on U.S. Pat. No. 6,090,149 such as platinum 2,3,7,8,12,12,17,18-octaethyl-21H,23H-porphine, i.e. PtOEP, iridium complex of Ir(PPY)<sub>3</sub>, and the like. And, the hole blocking layer 36 is formed of bathocuproine, i.e. BCP, cabazole biphenyl, i.e. CBP, N,N'-diphenyl-N,N'-bis-alpha-naphthylbenzidine, i.e. NPD.

[0018] OELD is divided into active and passive types in accordance with the driving systems. The passive type OELD follows a current driving system so that an efficiency of power consumption and a device reliability are decreased as a panel size increases. To settle such problems in case that a diagonal diameter of a panel is longer than 10 inches, the active type OELD using polysilicon thin film transistor-(poly-Si TFT) as driving devices is widely used.

[0019] Yet, when the polysilicon TFT is used as the driving device, the current technology fails to secure a uniformity of a thin film to drive OELD. And, the current technology also requires at least two TFTs for driving the OELD, thereby failing to secure a device reliability and a sufficient yield as well as realize a large-sized screen. And, the current technology also needs a complicated fabricating process, a high-vacuum process requiring an ultra vacuum environment and an expensive equipment for fine photolithography, and a high cleanness less than class 100, whereby a high cost of production is inevitable.

[0020] Meanwhile, at the stage of commercial use is a plasma display panel (hereinafter abbreviated PDP) using a memory function of plasma. Specifically, PDP is more suitable for a wide screen exceeding a size over 42 inches than OLED or Poly-Si TFT display.

[0021] FIG. 4 illustrates a schematic bird's-eye view of disassembled upper and lower plates of PDP for pixel areas according to a related art, in which shown is an example of a general AC type 3-electrodes surface discharge PDP disclosed on U.S. Pat. Nos. 5,420,602, 5,661,500, and 5,674,553. And, the pixel areas of the 3-electrodes surface discharge PDP are shown in the drawing.

[0022] And, FIG. 5 schematically illustrates cross-sectional views of the assembled upper and lower plates of PDP shown in FIG. 4 along bisecting lines A-A' and B-B', respectively, in which the cross-sectional views of the upper and lower plates are combined each other in case that the upper plate is rotated clockwise at 90° for the convenience of understanding.

[0023] Referring to FIG. 4 and FIG. 5, the pixel areas are provided by a front substrate 41 like a transparent plate such as a glass on an image display surface and a rear substrate 42 placed in parallel with the front substrate 41.

[0024] On the front substrate 41 formed are a plurality of transparent sustain electrodes 47 constructing pairs of electrodes X and Y on a surface confronting the rear substrate 42 with uniform intervals therebetween, a plurality of auxiliary sustain electrodes 48 formed on the sustain electrodes 47 respectively so as to reduce resistances of the sustain electrodes 26 respectively, a transparent dielectric layer 49 controlling a discharge current formed on a display (active) area including the auxiliary sustain and sustain electrodes 47 and 48, and a protecting layer 50 on the transparent dielectric layer 49 so as to protect the transparent dielectric layer 49 from plasma etch using of a material such as MgO or the like having a high secondary electron discharge coefficient to help to generate plasma with ease.

[0025] Meanwhile, on the rear substrate 42 formed are a plurality of stripe type barrier ribs 43 defining a plurality of discharge spaces so as to cross the sustain electrodes 47 at right angles respectively, a plurality of address electrodes 44 between the barrier ribs 43 so as to cross the sustain electrodes 47 at right angles respectively, a white back dielectric layer 45 covering the entire pixel areas including the address electrodes 44 so as to protect the address electrodes 44 as well as reflect lights emitted from a fluorescent (phosphor) layer 46, and a fluorescent layer 46 on the white back dielectric layer 45 and both inner walls of the respective barrier ribs 43 inside the respective discharge spaces so as to radiate visible rays on plasma discharge. Specifically, in order to increase the contrast ratio when the barrier ribs 43 are formed, lower barrier ribs 43A are firstly formed and then upper barrier ribs 43B are formed on the lower barrier ribs 43A.

[0026] Hg or one of noble gases such as He, Ne, Ar, Xe, Kr, Rn, and the like is used for plasma discharge. And, a mixed gas such as Ne—Xe, Ne—Xe—Ar, or the like is injected into the plasma discharge spaces at a pressure below atmosphere.

[0027] Explained in the following is an image display process of a random cell in the above-constructed surface discharge AC type PDP (hereinafter abbreviated AC-PDP) according to a related art.

[0028] The image display process mainly includes a total white and erase period carrying out a whole surface discharge and a whole surface erase, an address period bringing about a discharge selectively in accordance with display data, and a sustain period carrying out a sustain discharge on a lighted cell during the address period.

[0029] The total white and erase period includes an erase step of discharging a whole surface of the pixel area and removing generated wall charges so as to initialize the whole surface of PDP uniformly and constantly.

[0030] In order to discharge the whole surface of the pixel area, an initializing voltage of 150V~300V is applied between the X and Y electrodes constructing the pair of the sustain electrodes (line).

[0031] In the discharge space where a 'discharge' is generated, wall charges and charged particles exist. The total white and erase period is completed by applying an erase voltage enough not to generate the discharge to the X and Y electrodes so as to remove the wall charges and charged particles. The erase voltage, using the same potential of the initializing voltage, may be applied thereto for a short period of time so as not to generate the discharge.

[0032] The address period is carried out by applying a positive address pulse to the address electrode in order and by applying a negative scan pulse synchronized with the address pulse to the Y electrode in accordance with the display data selectively.

[0033] The scan pulse is applied to the pixel area having the display data only but fails to be applied to the pixel area having no display data. As a result, the discharge is generated from the cell to which the address and scan pulses are applied simultaneously. Hence, wall charges are accumulated in the lighted cell.

[0034] And, the sustain period generates a plurality of the number of times of 'sustain discharges' from the cell where the wall charges are accumulated by applying sustain discharge pulses to the X and Y electrodes alternately. In this case, a brightness of the corresponding cell is controlled by the number of times (frequency). The sustain discharge pulse should include a discharge voltage and a discharge period so that the discharge occurs in the cell selected during the address period, and vice versa.

[0035] However, the 3-electrodes surface discharge PDP excites the inorganic fluorescent material by vacuum UV rays generated from the plasma discharge and uses light irradiated from the inorganic fluorescent material.

[0036] Unfortunately, the 3-electrodes surface discharge PDP according to the related art having a decay time amounting to several-tens ms, thereby showing a residual image when presenting moving pictures.

[0037] Moreover, the 3-electrodes surface discharge PDP according to the related art has a low efficiency below 3 lm/W as well as a high driving voltage over 180V, whereby a cost of driving IC is too expensive.

## SUMMARY OF THE INVENTION

[0038] Accordingly, the present invention is directed to a plasma switched organic electroluminescent display that substantially obviates one or more of the problems due to limitations and disadvantages of the related art.

[0039] An object of the present invention is to provide a plasma switched organic electroluminescent display (PSOELD) enabling to emit light by organic electroluminescence having a decay time below several-tens ns as well as drive the display by a low driving voltage below 160V using a plasma discharge as a switch.

[0040] Another object of the present invention is to provide a plasma switched organic electroluminescent display (PSOELD) enabling to be fabricated by a simple and easy process using both a general PDP fabricating process and an OLED fabrication process.

[0041] Another object of the present invention is to provide a plasma switched organic electroluminescent display (PSOELD) enabling to reduce a cost of production by lowering a driving voltage to use a cheaper driving IC as well as provide a large-sized active type PSOELD with ease.

[0042] Additional features and advantages of the invention will be set forth in the description which follows, and in part will be apparent from the description, or may be learned by practice of the invention. The objectives and other advantages of the invention will be realized and attained by the structure particularly pointed out in the written description and claims hereof as well as the appended drawings.

[0043] To achieve these and other advantages, and in accordance with the purpose of the present invention as embodied and broadly described, a plasma switched organic electroluminescent display according to the present invention includes an electroluminescent part including a cathode layer, an electroluminescent layer on the cathode layer, and an anode layer on the electroluminescent layer, a first power supply unit connected electrically to the anode layer and disconnected electrically to the cathode layer so as to supply the electroluminescent layer with a first power, a plasma generating part generating a plasma wherein the plasma becomes contacted with the cathode layer, and a second power supply unit generating the plasma by supplying the plasma generating part with a second power, wherein the cathode layer is connected electrically to the first power supply unit through the plasma.

[0044] Preferably, the plasma switched electroluminescent display further includes an address electrode installed between the plasma generating part and the first power supply unit so as to connect the cathode layer electrically to the first power supply unit through the plasma.

[0045] Preferably, the first power is applied to the cathode layer by the plasma via the address electrode, and the cathode layer is a floating electrode.

[0046] Preferably, the electroluminescent layer is formed selectively one of high molecular organic electroluminescent material, low molecular electroluminescent material using fluorescence, and low molecular electroluminescent material using phosphorescence.

[0047] In another aspect of the present invention, a plasma switched organic electroluminescent display includes upper

and lower plates. The lower plate includes a first substrate, a plurality of sustain electrodes arranged on the first substrate in parallel each other so as to construct a plurality of sustain electrode pairs wherein each of the sustain electrode pairs comprises a pair of the sustain electrodes adjacent to each other, a dielectric layer on the first substrate including the sustain electrodes, and a plurality of barrier ribs formed on the dielectric layer to define a plurality of pixel areas constructing a plurality of rows and columns so that each of the sustain electrode pairs is placed in the corresponding row or column. The upper plate includes a second substrate, a plurality of address electrodes arranged on the second substrate so as to leave a predetermined interval each other wherein the address electrodes cross the sustain electrodes at right angle, a plurality of anode layers arranged on the second substrate so as to be placed next to the address electrodes in the pixel areas, respectively, a plurality of inner insulating/separating layers formed on the second substrate, each of the inner insulating/separating layers having an address electrode opening exposing the corresponding address electrode and an anode opening exposing the corresponding anode, a plurality of electroluminescent layers formed on the inner insulating/separating layers in the pixel areas, respectively, each of the electroluminescent layers contacted with the corresponding anode layer exposed through the anode opening, and a plurality of cathode layers formed on the electroluminescent layers, respectively.

[0048] Preferably, the plasma switched organic electroluminescent display further includes a protecting layer formed of MgO on the dielectric layer.

[0049] Preferably, the anode layers are formed selectively one of ITO(indium tin oxide) and IZO(indium zinc oxide).

[0050] Preferably, each of the anode openings extends to edges of a top of the corresponding anode layer so as to increase a contrast ratio of the display.

[0051] Preferably, the electroluminescent layers are formed by one of screen print, ink-jet print, dry film laminate, and vacuum evaporation using a shadow mask.

[0052] Preferably, the plasma switched organic electroluminescent display further includes a plurality of hole injection layers and a plurality of hole transport layers stacked in order between the anode layers and the electroluminescent layers, respectively, a plurality of hole blocking layers formed on the electroluminescent layers, respectively, and a plurality of electron transport layers formed on the hole blocking layers, respectively.

[0053] In a further aspect of the present invention, a plasma switched organic electroluminescent display includes upper and lower plates. The lower plate includes a first substrate, a plurality of sustain electrodes arranged on the first substrate in parallel each other so as to construct a plurality of sustain electrode pairs wherein each of the sustain electrode pairs comprises a pair of the sustain electrodes adjacent to each other, a dielectric layer on the first substrate including the sustain electrodes, a plurality of barrier ribs formed on the dielectric layer to define a plurality of pixel areas constructing a plurality of rows and columns so that each of the sustain electrode pairs is placed in the corresponding row or column, a protecting layer covering the dielectric layer exposed between the barrier ribs, and a plurality of exposed electrodes running in parallel

with each other on portions of the protecting layer corresponding to middle parts of the sustain electrode pairs, respectively. The upper plate includes a second substrate, a plurality of address electrodes arranged on the second substrate so as to leave a predetermined interval each other wherein the address electrodes cross the sustain electrodes at right angle, a plurality of anode layers arranged on the second substrate so as to be placed next to the address electrodes in the pixel areas, respectively, a plurality of inner insulating/separating layers formed on the second substrate, each of the inner insulating/separating layers having an anode opening exposing the corresponding anode layer, a plurality of electroluminescent layers formed on the inner insulating/separating layers in the pixel areas, respectively, each of the electroluminescent layers contacted with the corresponding anode layer exposed through the anode opening, and a plurality of cathode layers formed on the electroluminescent layers, respectively.

[0054] Preferably, each of the anode openings extends to edges of a top of the corresponding anode layer so as to increase a contrast ratio of the display.

[0055] Preferably, the electroluminescent layers are formed by one of screen print, ink-jet print, dry film laminate, and vacuum evaporation using a shadow mask.

[0056] Preferably, the plasma switched organic electroluminescent display further includes a plurality of hole injection layers and a plurality of hole transport layers stacked in order between the anode layers and the electroluminescent layers, respectively, a plurality of hole blocking layers formed on the electroluminescent layers, respectively, and a plurality of electron transport layers formed on the hole blocking layers, respectively.

[0057] In another further aspect of the present invention, a plasma switched organic electroluminescent display includes upper and lower plates. The lower plate includes a first substrate, a plurality of sustain electrodes arranged on the first substrate in parallel each other so as to construct a plurality of sustain electrode pairs wherein each of the sustain electrode pairs comprises a pair of the sustain electrodes adjacent to each other, a dielectric layer on the first substrate including the sustain electrodes, and a plurality of barrier ribs formed on the dielectric layer to define a plurality of pixel areas constructing a plurality of rows and columns so that each of the sustain electrode pairs is placed in the corresponding row or column. The upper plate includes a second substrate, a plurality of address electrodes arranged on the second substrate so as to leave a predetermined interval each other wherein the address electrodes cross the sustain electrodes at right angle, a plurality of exposed electrodes in parallel each other on the second substrate between the address electrodes, respectively, a plurality of anode layers arranged on the second substrate so as to be placed between the address electrodes and the exposed electrodes in the pixel areas, respectively, a plurality of inner insulating/separating layers formed on the second substrate including the anode layers and the anode layers except the exposed electrodes, each of the inner insulating/separating layers having an anode opening exposing the corresponding anode layer, a plurality of electroluminescent layers formed on the inner insulating/separating layers in the pixel areas, respectively, each of the electroluminescent layers contacted with the corresponding anode

layer exposed through the anode opening, and a plurality of cathode layers formed on the electroluminescent layers, respectively.

[0058] Preferably, each of the anode openings extends to edges of a top of the corresponding anode layer so as to increase a contrast ratio of the display.

[0059] Preferably, the electroluminescent layers are formed by one of screen print, ink-jet print, dry film laminate, and vacuum evaporation using a shadow mask.

[0060] Preferably, the plasma switched organic electroluminescent display further includes a plurality of hole transport layers inserted between the anode layers and the electroluminescent layers, respectively.

[0061] More preferably, the plasma switched organic electroluminescent display further includes a plurality of hole injection layers inserted between the anode layers and the hole transport layers, respectively.

[0062] Preferably, the plasma switched organic electroluminescent display further includes a plurality of electron transport layers inserted between the electroluminescent layers and the cathode layers, respectively.

[0063] More preferably, the plasma switched organic electroluminescent display further includes a plurality of hole blocking layers inserted between the electroluminescent layers and the electron transport layers, respectively.

[0064] Preferably, the plasma switched organic electroluminescent display further includes a protecting layer formed of MgO on the dielectric layer.

[0065] It is to be understood that both the foregoing general description and the following detailed description are exemplary and explanatory and are intended to provide further explanation of the invention as claimed.

#### BRIEF DESCRIPTION OF THE DRAWINGS

[0066] The accompanying drawings, which are included to provide a further understanding of the invention and are incorporated in and constitute a part of this specification, illustrate embodiments of the invention and together with the description serve to explain the principles of the invention.

[0067] In the drawings:

[0068] **FIG. 1** illustrates a cross-sectional view of a basic construction of OELD using a high molecular electroluminescent material according to a related art;

[0069] **FIG. 2** illustrates a cross-sectional view of a basic construction of OELD using a low molecular electroluminescent material for fluorescence according to a related art;

[0070] **FIG. 3** illustrates a cross-sectional view of a basic construction of OELD using a low molecular electroluminescent material for phosphorescence according to a related art;

[0071] **FIG. 4** illustrates a schematic bird's-eye view of disassembled upper and lower plates of PDP according to a related art;

[0072] **FIG. 5** illustrates schematically cross-sectional views of the upper and lower plates of PDP shown in **FIG. 4** along bisecting lines A-A' and B-B', respectively;

[0073] FIG. 6 illustrates a schematic bird's-eye view of PSOELD according to a first embodiment of the present invention;

[0074] FIG. 7 illustrates schematically cross-sectional views of upper and lower plates of PSOELD shown in FIG. 6 along bisecting lines A-A' and B-B', respectively;

[0075] FIG. 8A illustrates a cross-sectional diagram for explaining a plasma generated from a plasma discharge space in PSOELD according to the present invention;

[0076] FIG. 8B illustrates a cross-sectional diagram for explaining a plasma failing to occur in a plasma discharge space in PSOELD according to the present invention;

[0077] FIG. 9 illustrates a schematic bird's-eye view of PSOELD according to a second embodiment of the present invention;

[0078] FIG. 10 illustrates schematically cross-sectional views of upper and lower plates of PSOELD shown in FIG. 9 along bisecting lines A-A' and B-B', respectively;

[0079] FIG. 11 illustrates a schematic bird's-eye view of PSOELD according to a third embodiment of the present invention; and

[0080] FIG. 12 illustrates schematically cross-sectional views of upper and lower plates of PSOELD shown in FIG. 11 along bisecting lines A-A' and B-B', respectively.

#### DETAILED DESCRIPTION OF THE PREFERRED EMBODIMENTS

[0081] Reference will now be made in detail to the preferred embodiments of the present invention, examples of which are illustrated in the accompanying drawings. Where possible, the same reference numerals will be used to illustrate like elements throughout the specification. And, detailed component materials and techniques of the embodiments of the present invention include all those used for the related art.

[0082] [First Embodiment]

[0083] A plasma switched organic electroluminescent display (hereinafter abbreviated PSOELD) and a fabricating method thereof according to a first embodiment of the present invention are described as follows.

[0084] FIG. 6 illustrates a schematic birds-eye view of PSOELD according to a first embodiment of the present invention, and FIG. 7 illustrates schematically cross-sectional views of upper and lower plates of PSOELD shown in FIG. 6 along bisecting lines A-A' and B-B', respectively. And, FIG. 7 schematically illustrates cross-sectional views of the assembled upper and lower plates of PDP shown in FIG. 6, in which the cross-sectional views of upper and lower plates are combined each other in case that the upper plate is rotated clockwise at 90° for the convenience of understanding.

[0085] Referring to FIG. 6 and FIG. 7, PSOELD according to the first embodiment of the present invention includes an upper plate 110 and a lower plate 120.

[0086] The lower plate 120 includes a rear substrate 52, sustain electrodes 54, a dielectric layer 55, barrier ribs 53, and protecting layers 56. And, the upper plate 110 includes a front substrate 51, address electrodes 57, anode layers 58,

inner insulating/separating layers 59, anode contact holes 60, address electrode contact holes 61, electroluminescent layers 62, and cathode layers 63.

[0087] On the rear substrate 52 confronting to the front substrate 51, a plurality of the sustain electrodes 54 are formed in parallel each other like stripes by photolithography. In this case, every two X and Y of the sustain electrodes 54 construct a plurality of sustain electrode pairs. The sustain electrode X leaves an interval with the other sustain electrode Y as long as several tens~several hundreds  $\mu\text{m}$ , and the sustain electrodes 54 are several hundreds  $\mu\text{m}$  wide.

[0088] The dielectric layer 55 restricting a discharge current is formed on the rear substrate 52 several~several tens  $\mu\text{m}$  thick by screen print so as to cover the exposed surfaces of the sustain electrodes 54.

[0089] A plurality of the barrier ribs 53 are formed several hundreds  $\mu\text{m}$  tall on the dielectric layer 55 by repeating screen print about ten times so as to interrupt spaces to prevent a plasma discharge from diffusing into other cells. In this case, the barrier ribs 53 are formed to provide a lattice structure including a plurality of lattices so that a pair of the sustain electrodes 54 constructing the sustain electrode pair is placed in specific ones of the corresponding discharge spaces in the same row or column of the lattice structure.

[0090] And, a plurality of the protecting layers 56 are formed on the exposed surface of the dielectric layer 55 between the barrier ribs 53 respectively by vacuum evaporation using MgO or the like having a high discharge coefficient to protect the dielectric layer 55 from plasma etch as well as make a plasma occur with ease.

[0091] Meanwhile, as mentioned in the foregoing description, the upper plate 110 includes a front substrate 51, address electrodes 57, anode layers 58, inner insulating/separating layers 59, anode contact holes 60, address electrode contact holes 61, electroluminescent layers 62, and cathode layers 63.

[0092] On the front substrate 51 confronting the lower plate 120, a plurality of the address electrodes 57 are formed in parallel each other like stripes crossing the sustain electrodes 54 of the lower plate 120 respectively by patterning a conductive metal by photolithography.

[0093] A plurality of anode layers 58 like stripes in parallel each other are formed on the front substrate 51 between the address electrodes 57, respectively, using a transparent conductive material such as ITO (indium tin oxide), IZO (indium zinc oxide), or the like.

[0094] In order to increase a contrast ratio by cutting off light from a plasma discharge, a plurality of the inner insulating/separating layers 59 formed of a black material are formed on the front substrate 51 including the address electrodes 57 and anode layers 58.

[0095] In the inner insulating/separating layers 59 corresponding to the discharge spaces of the lower plate 120, a plurality of the through-hole type anode contact holes 60 and address electrode contact holes 61 exposing respectively portions of the anode layers 58 and address electrodes 57 are formed, respectively.

[0096] In this case, each of the anode contact holes 60 is formed to have a maximum exposed central area of the

anode layer **58** corresponding to the pixel area defined by the corresponding barrier ribs **53**, thereby enabling to prevent the anode layer **58** from being electrically connected to the cathode layer **63** right over the anode layer **58**.

[0097] Besides, each of the address electrode contact holes **61** is formed next to the corresponding anode contact hole **60** so as to expose a portion of the corresponding address electrode **57** in the discharge space defined by the corresponding barrier ribs **53**. And, each size of the address electrode contact holes **61** is smaller than that of the anode contact holes **60**.

[0098] Furthermore, the inner insulating/separating layers **59**, anode contact holes **60**, and address electrode contact holes **61** are formed by photolithography. And, the anode contact holes **60** and address electrode contact holes **61** are formed in the discharge spaces defined by the barrier ribs **53**, respectively.

[0099] A plurality of the electroluminescent layers **62** are formed on the inner insulating/separating layers **59** including the anode contact holes **60**, respectively. In this case, each of the electroluminescent layers **62** is formed rectangular enough to cover the corresponding anode contact hole **60**.

[0100] And, a plurality of the cathode layers **63** formed of a conductive metal such as Al or the like are formed on the electroluminescent layers **62**, respectively, by vacuum evaporation.

[0101] In this case, the electroluminescent layers **62** are formed one of high molecular organic electroluminescent material, low molecular electroluminescent material using fluorescence, low molecular electroluminescent material using phosphorescence, and the like.

[0102] The upper and lower plates **110** and **120** are aligned so that each of the anode contact holes **60** and address electrode contact holes **61** are placed between the corresponding barrier ribs **53** as well as confront the corresponding sustain electrode pair X and Y. A mixed gas of Ne—Xe or Ne—Xe—Ar is injected into the respective discharge spaces between the barrier ribs **53** at a pressure below atmosphere, thereby enabling to generate plasma. For instance, the mixed gas of Ne(96%)—Xe(4%) is injected at 500 torr to generate plasma.

[0103] When the electroluminescent layers **62** are formed of the high molecular organic electroluminescent material by ink-jet or screen print, hole transport layers are further formed on the anode layers **58** respectively so that the electroluminescent layers **62** are preferably placed on the hole transport layers respectively.

[0104] When the electroluminescent layers **62** are formed of the low molecular organic electroluminescent material using fluorescence by vacuum evaporation, both hole injection layers and hole transport layers are further inserted between the anode layers **58** and the electroluminescent layers **62**, respectively, and electron transport layers are further inserted between the electroluminescent layers **62** and the cathode layers **63**, respectively.

[0105] And, When the electroluminescent layers **62** are formed of the low molecular organic electroluminescent material using phosphorescence by vacuum evaporation, both hole injection layers and hole transport layers are

further inserted between the anode layers **58** and the electroluminescent layers **62**, respectively, and both hole blocking layers and electron transport layers are further inserted between the electroluminescent layers **62** and the cathode layers **63**, respectively.

[0106] FIG. 8A illustrates a cross-sectional diagram for explaining a plasma generated from a plasma discharge space in PSOELD according to the present invention, and FIG. 8B illustrates a cross-sectional diagram for explaining a plasma failing to occur in a plasma discharge space in PSOELD according to the present invention. In FIG. 8A and FIG. 8B using the same numerals in FIG. 6 and FIG. 7, the cross-sectional views of upper and lower plates are combined each other in case that the upper plate is rotated clockwise at 90° for the convenience of understanding.

[0107] Referring to FIG. 8A and FIG. 8B, the organic electroluminescent layer **62** is inserted between the anode and cathode layers **58** and **63**. And, the plasma discharge space **64**, from which plasma is generated, is defined by the cathode layer **63**, address electrode **57**, protecting layer **56**, and barrier ribs **53** surrounding the protecting layer **56**.

[0108] Through the total white and erase period and the address period applied generally to a 3-electrodes surface discharge structure for operating PSOELD, when a sustain voltage is applied to a first power source V1 while wall charges are formed on the protecting layer **56** in the cell selected by the address period, plasma PLASMA, as shown in FIG. 8A, is generated in the plasma discharge space **64** so that the cathode layer **63** is electrically connected (turned on) to the address electrode **57** through the generated plasma PLASMA. Hence, the organic electroluminescent layer **62** emits light by a second power source V2.

[0109] Yet, another cell unselected by the address period fails to form wall charges on the protecting layer **56**, thereby unable to generate the plasma in the plasma discharge space **64** despite applying the sustain voltage to the first power source V1. Thus, the cathode layer **63** and the address electrode **57** maintains turned off, whereby the organic electroluminescent layer **62** fails to emit light.

[0110] Therefore, the plasma occurrence in the plasma discharge space **64** functions as a switch determining whether the organic electroluminescent layer **62** emits light or not.

[0111] [Second Embodiment]

[0112] FIG. 9 illustrates a schematic bird's-eye view of PSOELD according to a second embodiment of the present invention, and FIG. 10 illustrates schematically cross-sectional views of upper and lower plates of PSOELD shown in FIG. 9 along bisecting lines A-A' and B-B', respectively. And, FIG. 10 schematically illustrates cross-sectional views of the assembled upper and lower plates of PDP shown in FIG. 9, in which the cross-sectional views of upper and lower plates are combined each other in case that the upper plate is rotated clockwise at 90° for the convenience of understanding.

[0113] Referring to FIG. 9 and FIG. 10, PSOELD according to the second embodiment of the present invention includes an upper plate **130** and a lower plate **140**.

[0114] The lower plate **140** includes a rear substrate **72**, sustain electrodes **74**, a dielectric layer **75**, barrier ribs **73**,

protecting layers **76**, and exposed electrodes **85**. And, the upper plate **130** includes a front substrate **71**, address electrodes **77**, anode layers **78**, inner insulating/separating layers **79**, anode contact holes **80**, electroluminescent layers **82**, and cathode layers **83**.

[0115] On the rear substrate **72** confronting to the front substrate **71**, a plurality of the sustain electrodes **74** are formed in parallel each other like stripes by photolithography. In this case, every two X and Y of the sustain electrodes **74** construct a plurality of sustain electrode pairs. The sustain electrode X leaves an interval with the other sustain electrode Y as long as several tens~several hundreds  $\mu\text{m}$ , and each of the sustain electrodes **74** is several hundreds  $\mu\text{m}$  wide.

[0116] The dielectric layer **75** restricting a discharge current is formed on the rear substrate **72** several~several tens  $\mu\text{m}$  thick by screen print so as to cover the exposed surfaces of the sustain electrodes **74**.

[0117] A plurality of the barrier ribs **73** are formed several hundreds  $\mu\text{m}$  tall on the dielectric layer **75** by repeating screen print about ten times so as to interrupt spaces to prevent a plasma discharge from diffusing into other cells. In this case, the barrier ribs **73** are formed to provide a lattice structure including a plurality of lattices so that a pair of the sustain electrodes **74** constructing the sustain electrode pair is placed in specific ones of the corresponding discharge spaces in the same row or column of the lattice structure.

[0118] A plurality of the protecting layers **76** are formed on the exposed surface of the dielectric layer **75** between the barrier ribs **73** respectively by vacuum evaporation using MgO or the like having a high discharge coefficient to protect the dielectric layer **75** from plasma etch as well as make a plasma occur with ease.

[0119] And, a plurality of the exposed electrodes **85** are formed on the protecting layers **76** overlapped with the middle parts between the two sustain electrodes **74** constructing the sustain electrode pair X and Y in the discharge spaces, respectively. In this case, the exposed electrodes **85** are formed by vacuum evaporation using a shadow mask so as to be arranged on the protecting layers like stripes in parallel with the sustain electrodes **74**, respectively.

[0120] Meanwhile, as mentioned in the foregoing description, the upper plate **130** includes the front substrate **71**, address electrodes **77**, anode layers **78**, inner insulating/separating layers **79**, anode contact holes **80**, electroluminescent layers **82**, and cathode layers **83**.

[0121] On the front substrate **71** confronting the lower plate **140**, a plurality of the address electrodes **77** are formed in parallel each other like stripes crossing the sustain electrodes **74** of the lower plate **140** at right angle respectively by patterning a conductive metal by photolithography.

[0122] A plurality of anode layers **78** like stripes in parallel with the address electrodes **77** are formed on the front substrate **71** between the address electrodes **77**, respectively, using a transparent conductive material such as ITO(indium tin oxide), IZO(indium zinc oxide), or the like.

[0123] In order to increase a contrast ratio by cutting off light from a plasma discharge, a plurality of the inner insulating/separating layers **79** formed of a black material

are formed on the front substrate **51** including the address electrodes **77** and anode layers **78**.

[0124] In the inner insulating/separating layers **79** corresponding to the discharge spaces of the lower plate **140** respectively, a plurality of the through-hole type anode contact holes **80** exposing portions of the anode layers **78** are formed, respectively.

[0125] In this case, each of the anode contact holes **80** is formed to have a maximum exposed central area of the anode layer **78** corresponding to the pixel area defined by the corresponding barrier ribs **73**, thereby enabling to prevent the anode layer **78** from being electrically connected-(shorted) to the cathode layer **83** over the anode layer **78**.

[0126] Besides, the inner insulating/separating layers **79** and anode contact holes **80** are formed by photolithography. And, the anode contact holes **80** are formed in the discharge spaces defined by the barrier ribs **73**, respectively.

[0127] A plurality of the electroluminescent layers **82** are formed on the inner insulating/separating layers **79** including the anode contact holes **80**, respectively. In this case, each of the electroluminescent layers **82** is formed rectangular enough to cover the corresponding anode contact hole **80**.

[0128] And, a plurality of the cathode layers **83** formed of a conductive metal such as Al or the like are formed on the electroluminescent layers **82**, respectively, by vacuum evaporation.

[0129] In this case, the electroluminescent layers **82** are formed one of high molecular organic electroluminescent material, low molecular electroluminescent material using fluorescence, low molecular electroluminescent material using phosphorescence, and the like.

[0130] The upper and lower plates **130** and **140** are aligned so that each of the anode contact holes **80** is placed between the corresponding barrier ribs **73** as well as confronts the corresponding sustain electrode pair X and Y. A mixed gas of Ne—Xe or Ne—Xe—Ar is injected into the respective discharge spaces between the barrier ribs **73** at a pressure below atmosphere, thereby enabling to generate plasma. For instance, the mixed gas of Ne(96%)—Xe(4%) is injected at 500 torr to generate plasma.

[0131] When the electroluminescent layers **82** are formed of the high molecular organic electroluminescent material by ink-jet or screen print, hole transport layers are further formed on the anode layers **78** respectively so that the electroluminescent layers **82** are preferably placed on the hole transport layers respectively.

[0132] When the electroluminescent layers **82** are formed of the low molecular organic electroluminescent material using fluorescence by vacuum evaporation, both hole injection layers and hole transport layers are further inserted between the anode layers **78** and the electroluminescent layers **82**, respectively, and electron transport layers are further inserted between the electroluminescent layers **82** and the cathode layers **83**, respectively.

[0133] And, When the electroluminescent layers **82** are formed of the low molecular organic electroluminescent material using phosphorescence by vacuum evaporation, both hole injection layers and hole transport layers are

further inserted between the anode layers **78** and the electroluminescent layers **82**, respectively, and both hole blocking layers and electron transport layers are further inserted between the electroluminescent layers **82** and the cathode layers **83**, respectively.

[0134] [Third Embodiment]

[0135] FIG. 11 illustrates a schematic bird's-eye view of PSOELD according to a third embodiment of the present invention, and FIG. 12 illustrates schematically cross-sectional views of upper and lower plates of PSOELD shown in FIG. 11 along bisecting lines A-A' and B-B', respectively. And, FIG. 12 schematically illustrates cross-sectional views of the assembled upper and lower plates of PDP shown in FIG. 11, in which the cross-sectional views of upper and lower plates are combined each other in case that the upper plate is rotated clockwise at 90° for the convenience of understanding.

[0136] Referring to FIG. 11 and FIG. 12, PSOELD according to the third embodiment of the present invention includes an upper plate **150** and a lower plate **160**.

[0137] The lower plate **160** includes a rear substrate **92**, sustain electrodes **94**, a dielectric layer **95**, barrier ribs **93**, and protecting layers **96**. And, the upper plate **150** includes a front substrate **91**, address electrodes **97**, anode layers **98**, inner insulating/separating layers **99**, anode contact holes **100**, electroluminescent layers **102**, cathode layers **103**, and exposed electrodes **105**.

[0138] On the rear substrate **92** confronting to the front substrate **91**, a plurality of the sustain electrodes **94** are formed in parallel each other like stripes by photolithography. In this case, every two X and Y of the sustain electrodes **94** construct a plurality of sustain electrode pairs. The sustain electrode X leaves an interval with the other sustain electrode Y as long as several tens~several hundreds  $\mu\text{m}$ , and the sustain electrodes **94** are several hundreds  $\mu\text{m}$  wide.

[0139] The dielectric layer **95** restricting a discharge current is formed on the rear substrate **92** several~several tens  $\mu\text{m}$  thick by screen print so as to cover the exposed surfaces of the sustain electrodes **94**.

[0140] A plurality of the barrier ribs **93** are formed several hundreds  $\mu\text{m}$  tall on the dielectric layer **95** by repeating screen print about ten times so as to interrupt spaces to prevent a plasma discharge from diffusing into other cells. In this case, the barrier ribs **93** are formed to provide a lattice structure including a plurality of lattices so that a pair of the sustain electrodes **94** constructing the sustain electrode pair is placed in specific ones of the corresponding discharge spaces in the same row or column of the lattice structure.

[0141] And, a plurality of the protecting layers **96** are formed on the exposed surface of the dielectric layer **95** between the barrier ribs **93** respectively by vacuum evaporation using MgO or the like having a high discharge coefficient to protect the dielectric layer **95** from plasma etch as well as make a plasma occur with ease.

[0142] Meanwhile, as mentioned in the foregoing description, the upper plate **150** includes the front substrate **91**, address electrodes **97**, anode layers **98**, inner insulating/separating layers **99**, anode contact holes **100**, electroluminescent layers **102**, cathode layers **103**, and exposed electrodes **105**.

[0143] On the front substrate **91** confronting the lower plate **160**, a plurality of the address electrodes **97** and exposed electrodes **105** are formed alternately in parallel each other like stripes crossing the sustain electrodes **94** of the lower plate **160** at right angle respectively by patterning a conductive metal by photolithography.

[0144] A plurality of anode layers **98** like stripes between and in parallel with the address electrodes **97** and the exposed electrodes **105** are formed on the front substrate **91**, respectively, using a transparent conductive material such as ITO(indium tin oxide), IZO(indium zinc oxide), or the like.

[0145] In order to increase a contrast ratio by cutting off light from a plasma discharge, a plurality of the inner insulating/separating layers **99** formed of a black material are formed on the front substrate **91** including the address electrodes **77** and anode layers **78** so as to expose the exposed electrodes **105**.

[0146] In the inner insulating/separating layers **99** corresponding to the discharge spaces of the lower plate **160** respectively, a plurality of the through-hole type anode contact holes **100** exposing portions of the anode layers **98** are formed, respectively.

[0147] In this case, each of the anode contact holes **100** is formed to have a maximum exposed central area of the anode layer **98** corresponding to the pixel area defined by the corresponding barrier ribs **93**, thereby enabling to prevent the anode layer **98** from being electrically connected-(shorted) to the corresponding cathode layer **103** over the anode layer **98**.

[0148] Besides, the inner insulating/separating layers **99** and anode contact holes **100** are formed by photolithography. And, the anode contact holes **100** are formed in the discharge spaces defined by the barrier ribs **93**, respectively.

[0149] A plurality of the electroluminescent layers **102** are formed on the inner insulating/separating layers **99** including the anode contact holes **100**, respectively. In this case, each of the electroluminescent layers **102** is formed rectangular enough to cover the corresponding anode contact hole **100**.

[0150] And, a plurality of the cathode layers **103** formed of a conductive metal such as Al or the like are formed on the electroluminescent layers **102**, respectively, by vacuum evaporation.

[0151] In this case, the electroluminescent layers **102** are formed one of high molecular organic electroluminescent material, low molecular electroluminescent material using fluorescence, low molecular electroluminescent material using phosphorescence, and the like.

[0152] The upper and lower plates **150** and **160** are aligned so that each of the anode contact holes **100** is placed between the corresponding barrier ribs **93** as well as confronts the corresponding sustain electrode pair X and Y. A mixed gas of Ne—Xe or Ne—Xe—Ar is injected into the respective discharge spaces between the barrier ribs **93** at a pressure below atmosphere, thereby enabling to generate plasma. For instance, the mixed gas of Ne(96%)—Xe(4%) is injected at 500 torr to generate plasma.

[0153] When the electroluminescent layers **102** are formed of the high molecular organic electroluminescent

material by ink-jet or screen print, hole transport layers are further formed on the anode layers **98** respectively so that the electroluminescent layers **102** are preferably placed on the hole transport layers respectively.

[0154] When the electroluminescent layers **102** are formed of the low molecular organic electroluminescent material using fluorescence by vacuum evaporation, both hole injection layers and hole transport layers are further inserted between the anode layers **98** and the electroluminescent layers **102**, respectively, and electron transport layers are further inserted between the electroluminescent layers **102** and the cathode layers **103**, respectively.

[0155] And, When the electroluminescent layers **102** are formed of the low molecular organic electroluminescent material using phosphorescence by vacuum evaporation, both hole injection layers and hole transport layers are further inserted between the anode layers **98** and the electroluminescent layers **102**, respectively, and both hole blocking layers and electron transport layers are further inserted between the electroluminescent layers **102** and the cathode layers **103**, respectively.

[0156] As mentioned in the above description, the photoluminescent material of the plasma switched organic photoluminescent display according to the present invention emits light not by a current but by ultraviolet rays irradiated from plasma.

[0157] Accordingly, the PSOELD according to the present invention enables to be driven by a driving voltage lower than that of the PDP according to the related art by using a plasma switch as a driving device playing a role as a switch only instead of a purpose for irradiating massive vacuum UV rays from the generation of plasma.

[0158] And, the present invention enables to fabricate a high efficient display free from a residual color effect by emitting light through an organic electroluminescent display.

[0159] Moreover, compared to the display using TFT as a driving device, the present invention enables to be fabricated by a simple fabricating process.

[0160] Furthermore, the present invention enables to provide a large-sized display with ease.

[0161] The foregoing embodiments are merely exemplary and are not to be construed as limiting the present invention. The present teachings can be readily applied to other types of apparatuses. The description of the present invention is intended to be illustrative, and not to limit the scope of the claims. Many alternatives, modifications, and variations will be apparent to those skilled in the art.

What is claimed is:

1. A plasma switched electroluminescent display comprising:

an electroluminescent part including a cathode layer, an electroluminescent layer on the cathode layer, and an anode layer on the electroluminescent layer;

a first power supply unit connected electrically to the anode layer and disconnected electrically to the cathode layer so as to supply the electroluminescent layer with a first power;

a plasma generating part generating a plasma wherein the plasma becomes contacted with the cathode layer; and

a second power supply unit generating the plasma by supplying the plasma generating part with a second power,

wherein the cathode layer is connected electrically to the first power supply unit through the plasma.

2. The plasma switched electroluminescent display of claim 1, further comprising an address electrode installed between the plasma generating part and the first power supply unit so as to connect the cathode layer electrically to the first power supply unit through the plasma.

3. The plasma switched electroluminescent display of claim 2, wherein the first power is applied to the cathode layer by the plasma via the address electrode.

4. The plasma switched electroluminescent display of claim 1, wherein the cathode layer is a floating electrode.

5. The plasma switched electroluminescent display of claim 1, wherein the electroluminescent layer is formed selectively one of high molecular organic electroluminescent material, low molecular electroluminescent material using fluorescence, and low molecular electroluminescent material using phosphorescence.

6. A plasma switched organic electroluminescent display comprising:

a lower plate comprising:

a first substrate;

a plurality of sustain electrodes arranged on the first substrate in parallel each other so as to construct a plurality of sustain electrode pairs wherein each of the sustain electrode pairs comprises a pair of the sustain electrodes adjacent to each other;

a dielectric layer on the first substrate including the sustain electrodes; and

a plurality of barrier ribs formed on the dielectric layer to define a plurality of pixel areas constructing a plurality of rows and columns so that each of the sustain electrode pairs is placed in the corresponding row or column; and

an upper plate comprising:

a second substrate;

a plurality of address electrodes arranged on the second substrate so as to leave a predetermined interval each other wherein the address electrodes cross the sustain electrodes at right angle;

a plurality of anode layers arranged on the second substrate so as to be placed next to the address electrodes in the pixel areas, respectively;

a plurality of inner insulating/separating layers formed on the second substrate, each of the inner insulating/separating layers having an address electrode opening exposing the corresponding address electrode and an anode opening exposing the corresponding anode;

a plurality of electroluminescent layers formed on the inner insulating/separating layers in the pixel areas, respectively, each of the electroluminescent layers

- contacted with the corresponding anode layer exposed through the anode opening; and
- a plurality of cathode layers formed on the electroluminescent layers, respectively.
7. The plasma switched organic electroluminescent display of claim 6, further comprising a protecting layer formed of MgO on the dielectric layer.
8. The plasma switched organic electroluminescent display of claim 6, wherein the anode layers are formed selectively one of ITO(indium tin oxide) and IZO(indium zinc oxide).
9. The plasma switched organic electroluminescent display of claim 6, wherein each of the anode openings extends to edges of a top of the corresponding anode layer so as to increase a contrast ratio of the display.
10. The plasma switched organic electroluminescent display of claim 6, wherein the electroluminescent layers are formed by one of screen print, ink-jet print, dry film laminate, and vacuum evaporation using a shadow mask.
11. The plasma switched organic electroluminescent display of claim 6, further comprising:
- a plurality of hole injection layers and a plurality of hole transport layers stacked in order between the anode layers and the electroluminescent layers, respectively;
  - a plurality of hole blocking layers formed on the electroluminescent layers, respectively; and
  - a plurality of electron transport layers formed on the hole blocking layers, respectively.
12. A plasma switched organic electroluminescent display comprising:
- a lower plate comprising:
    - a first substrate;
    - a plurality of sustain electrodes arranged on the first substrate in parallel each other so as to construct a plurality of sustain electrode pairs wherein each of the sustain electrode pairs comprises a pair of the sustain electrodes adjacent to each other;
    - a dielectric layer on the first substrate including the sustain electrodes;
    - a plurality of barrier ribs formed on the dielectric layer to define a plurality of pixel areas constructing a plurality of rows and columns so that each of the sustain electrode pairs is placed in the corresponding row or column;
    - a protecting layer covering the dielectric layer exposed between the barrier ribs; and
    - a plurality of exposed electrodes running in parallel with each other on portions of the protecting layer corresponding to middle parts of the sustain electrode pairs, respectively; and
  - an upper plate comprising:
    - a second substrate;
    - a plurality of address electrodes arranged on the second substrate so as to leave a predetermined interval each other wherein the address electrodes cross the sustain electrodes at right angle;
- a plurality of anode layers arranged on the second substrate so as to be placed next to the address electrodes in the pixel areas, respectively;
- a plurality of inner insulating/separating layers formed on the second substrate, each of the inner insulating/separating layers having an anode opening exposing the corresponding anode layer;
- a plurality of electroluminescent layers formed on the inner insulating/separating layers in the pixel areas, respectively, each of the electroluminescent layers contacted with the corresponding anode layer exposed through the anode opening; and
- a plurality of cathode layers formed on the electroluminescent layers, respectively.
13. The plasma switched organic electroluminescent display of claim 12, wherein each of the anode openings extends to edges of a top of the corresponding anode layer so as to increase a contrast ratio of the display.
14. The plasma switched organic electroluminescent display of claim 12, wherein the electroluminescent layers are formed by one of screen print, ink-jet print, dry film laminate, and vacuum evaporation using a shadow mask.
15. The plasma switched organic electroluminescent display of claim 12, further comprising:
- a plurality of hole injection layers and a plurality of hole transport layers stacked in order between the anode layers and the electroluminescent layers, respectively;
  - a plurality of hole blocking layers formed on the electroluminescent layers, respectively; and
  - a plurality of electron transport layers formed on the hole blocking layers, respectively.
16. A plasma switched organic electroluminescent display comprising:
- a lower plate comprising:
    - a first substrate;
    - a plurality of sustain electrodes arranged on the first substrate in parallel each other so as to construct a plurality of sustain electrode pairs wherein each of the sustain electrode pairs comprises a pair of the sustain electrodes adjacent to each other;
    - a dielectric layer on the first substrate including the sustain electrodes; and
    - a plurality of barrier ribs formed on the dielectric layer to define a plurality of pixel areas constructing a plurality of rows and columns so that each of the sustain electrode pairs is placed in the corresponding row or column; and
  - an upper plate comprising:
    - a second substrate;
    - a plurality of address electrodes arranged on the second substrate so as to leave a predetermined interval each other wherein the address electrodes cross the sustain electrodes at right angle;
    - a plurality of exposed electrodes in parallel each other on the second substrate between the address electrodes, respectively;

- a plurality of anode layers arranged on the second substrate so as to be placed between the address electrodes and the exposed electrodes in the pixel areas, respectively;
- a plurality of inner insulating/separating layers formed on the second substrate including the anode layers and the anode layers except the exposed electrodes, each of the inner insulating/separating layers having an anode opening exposing the corresponding anode layer;
- a plurality of electroluminescent layers formed on the inner insulating/separating layers in the pixel areas, respectively, each of the electroluminescent layers contacted with the corresponding anode layer exposed through the anode opening; and
- a plurality of cathode layers formed on the electroluminescent layers, respectively.
- 17.** The plasma switched organic electroluminescent display of claim 16, wherein each of the anode openings extends to edges of a top of the corresponding anode layer so as to increase a contrast ratio of the display.
- 18.** The plasma switched organic electroluminescent display of claim 16, wherein the electroluminescent layers are formed by one of screen print, ink-jet print, dry film laminate, and vacuum evaporation using a shadow mask.
- 19.** The plasma switched organic electroluminescent display of claim 16, further comprising a plurality of hole transport layers inserted between the anode layers and the electroluminescent layers, respectively.
- 20.** The plasma switched organic electroluminescent display of claim 19, further comprising a plurality of hole injection layers inserted between the anode layers and the hole transport layers, respectively.
- 21.** The plasma switched organic electroluminescent display of claim 16, further comprising a plurality of electron transport layers inserted between the electroluminescent layers and the cathode layers, respectively.
- 22.** The plasma switched organic electroluminescent display of claim 21, further comprising a plurality of hole blocking layers inserted between the electroluminescent layers and the electron transport layers, respectively.
- 23.** The plasma switched organic electroluminescent display of claim 16, further comprising a protecting layer formed of MgO on the dielectric layer.

\* \* \* \* \*

专利名称(译)	等离子切换有机电致发光显示器		
公开(公告)号	<a href="#">US20020063525A1</a>	公开(公告)日	2002-05-30
申请号	US09/995642	申请日	2001-11-29
[标]申请(专利权)人(译)	CHOI DO HYUN BYUN BYUNG HYUN 易刘承俊		
申请(专利权)人(译)	崔DO-HYUN BYUN炳HYUN 易SEUNG-JUN		
当前申请(专利权)人(译)	崔DO-HYUN BYUN炳HYUN 易SEUNG-JUN		
[标]发明人	CHOI DO HYUN BYUN BYUNG HYUN YI SEUNG JUN		
发明人	CHOI, DO-HYUN BYUN, BYUNG-HYUN YI, SEUNG-JUN		
IPC分类号	H01L51/50 G09F9/30 G09G3/32 H01J17/48 H01L27/32 H01J17/49 H01J1/62		
CPC分类号	G09G3/3208 G09G2300/08 H01L27/32 H01J2217/4025 H01J11/00		
优先权	1020000071445 2000-11-29 KR 1020010069888 2001-11-09 KR		
其他公开文献	US6781309		
外部链接	<a href="#">Espacenet</a> <a href="#">USPTO</a>		

摘要(译)

描述了一种等离子体切换有机电致发光显示器，其包括电致发光部分，该电致发光部分包括阴极层，阴极层上的电致发光层，以及电致发光层上的阳极层，第一电源单元，电连接到阳极层并且电连接阴极层向阴极层提供第一电力，等离子体产生部分产生等离子体，其中等离子体与阴极层接触，第二电源装置产生等离子体，通过向等离子体产生部分提供第二电源，其中阴极层通过等离子体电连接到第一电源单元，从而能够通过有机电致发光发光，并且使用等离子体放电作为开关通过低驱动电压驱动显示器。

